

CUNA2

User manual



 ARGOSDYNE

Contents

Drone safety precautions

1. CUNA2 introduction

2. Configuration

- ① CUNA2 basic configuration
- ② CUNA2 whole block configuration
- ③ Door opening and closing part
- ④ Top pad part
- ⑤ Bottom mechanism part
- ⑥ CUNA2 set up site conditions

3. Operation

- ① Power on/off
- ② Drone precision landing
- ③ Drone automatic charging

4. Remote control

- ① argosALES – Check the status through the GCS program
- ② argosALES – Operation control through the GCS program

5. Reference

- ① CUNA2 specification
- ② Other notes

6. FAQ and Customer support



Drone safety precautions

○ Pilot compliance

The pilot of an ultralight flying device (drone) must comply with the regulations stipulated by the decree of the Ministry of Land, Infrastructure, and Transport to prevent damage to human life or property due to the ultralight flying device.

- No night flights after sunset until sunrise
- Non-visible flights where it is difficult to fly safely due to fog, rain, etc. and flight cannot be visually confirmed are prohibited
- Control area (within a radius of 9.3 km from the airfield) prohibited from flying
- Flights are prohibited in areas where flights are prohibited due to defense and security reasons, such as the border area, Gangbuk in Seoul, and nuclear power plants (radius 18.6 km), airports or aircraft take-off and landing airfields
- No flying in the airspace (altitude above 150m) where the flight route of the aircraft is installed.
- Flying is prohibited in places where there is a risk of personal injury if the aircraft falls, such as in densely populated areas or in the sky where there are many people.
- No dropping of falling objects during flight
- No flying while intoxicated

Tip. No-fly zone check app: Ready to fly

○ Safety checks

Please be sure to conduct safety inspections of the ultralight flying device (drone) before, during, and after flight.

- Pre-flight Safety Check
 - Check remote controller on and charging status
 - Connect battery power and check charging status
 - Check for propeller breakage and motor engagement
 - Check the appearance of arms, landing gear, frame, etc.
 - Check airspace, weather, obstacles and secure a safe distance (15m)
 - Final check of communication status such as GPS, wifi, etc.
- Operation check after take-off
 - Flight after checking forward, backward, left and right movements, up and down, left and right rotational movements

- Post-flight safety checks
 - Disconnect battery power
 - Remote Controller off
 - Check propeller, motor, arm, landing gear, frame, etc

1. CUNA2 drone station introduction

The core of drone automatic operation system, drone automatic charging station

CUNA2 is an industrial drone automatic charging station that supports Argosdyne's drone automatic operation platform, the Rondo Mobility System, and automatic charging and automatic takeoff and landing of drones East Sea.

Drone stations are essential elements for industrial sites that want to use drones to perform continuous and repetitive automated flight missions, and when multiple stations are used, a wider flight is possible without considering the return flight distance, which is a means to practically overcome the limited flight time and distance of drones. It is also an efficient drone operation solution that can automate the entire drone operation process without the hassle of human battery replacement.

CUNA2 is embedded in a dome structure to protect the base station with the charging module from the external environment, and it is paired with the drone to perform the automatic charging function.

CUNA2 works in conjunction with argosALES, a ground control system for drones that can remotely control multiple drones and stations, to complete the Rondo Mobility System, an automated drone operation system.

CUNA2 is a fixed drone station that can be deployed and operated at a designated location for extended periods of time, protecting the base station from the external environment and providing camera-based precision landing guidance, remote charging control, and internal condition monitoring.



Reference

Detailed specifications such as communication and charging modules of CUNA2, whether the level of water and dust protection is applied, etc., are determined through consultation according to the customer's requirements. .

2. Configuration

CUNA2 consists of a dome structure to protect the base station and drone from external environments such as snow, rain, strong wind, and foreign objects, and is a core device that provides precise takeoff, landing, and charging functions for the drone's mission through the upper opening and closing.

① CUNA2 Basic configuration

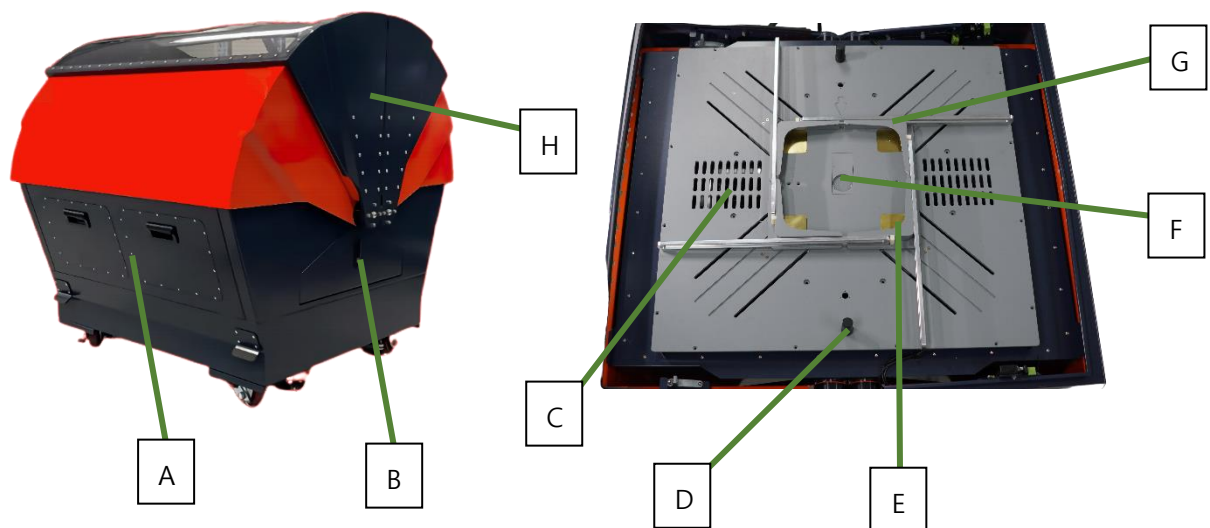

PART	NAME	PART	NAME
A.	Control management door	B.	Power management door
C.	Cooling and heating device	D.	GPS module
E.	Charging pad	F.	Landing Beacon
G.	Drone alignment actuator	H.	Top opening door

② CUNA2 whole block configuration

CUNA2 Block Diagram

Cuna-2 Block Diagram

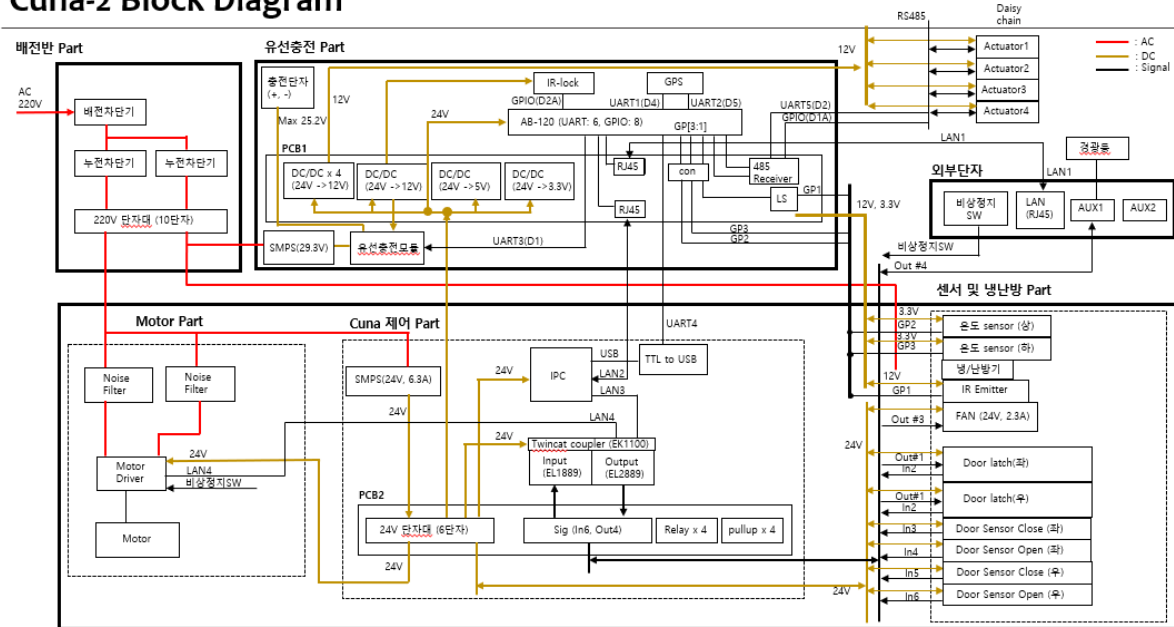

③ Door opening and closing part

- For landing and storage of Argosdyne's drones or drones equipped with automatic precision landing modules, a dome-shaped door that opens left and right opens and closes to store the drone and protect it from the external environment at the same time.
- The door opening and closing structure is composed of synthetic resin material for fast GPS reception, and the lower opening and closing door is composed of iron material.

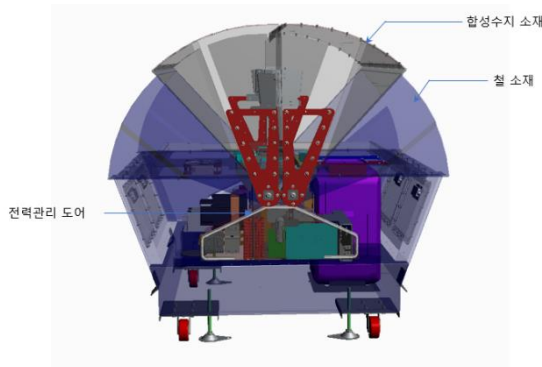

④ Top pad part

- Automatic charging of the drone
 - The charging terminal and the charging pad mounted on the drone landing skid come into contact to charge the battery without the need for the pilot to replace the battery so that the mission can be maintained.
 - A charging pad position that can be charged through the charging terminal of the drone arranged in the center.
- Drone alignment actuator
 - The four drone alignment actuators located on the top are configured to move diagonally to move the drone to the center and to be automatically charged.
- Drone precision landing guidance
 - Thanks to the vision system using infrared light, precise landing at the drone station can be made without the need for pilot control.
 - After receiving the command to land at the station, the drone arrives over the station and descends while finding the correct landing site on its own, landing precisely at the station.
- GPS
 - Receives signals transmitted from GPS satellites and informs CUNA2 location information
- Cooling and heating function (Can keep the inside of CUNA2 at the right temperature for all seasons)
 - Cooling capacity : 450W
 - Heating capacity : 400W
 - noise : 39dB ~ 41dB
 - With the built-in temperature sensor, the upper and lower CUNA2 top and bottom temperatures can be checked and adjusted remotely.

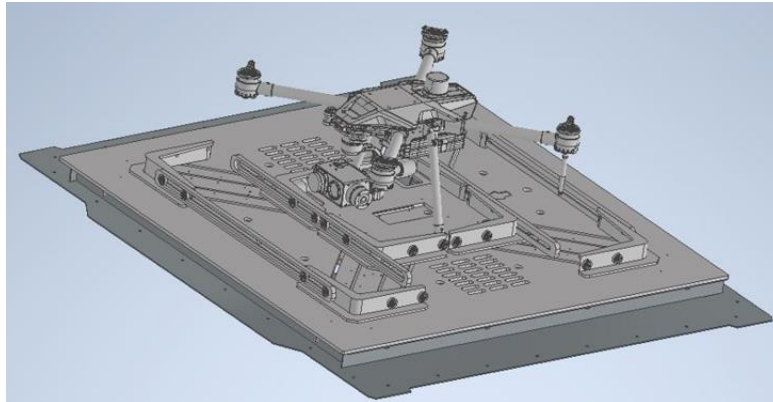

⑤ Bottom mechanism part

- Power Management and Control Management
 - Sensors and motion control for power delivery, station operation and drone charging, precision takeoff and landing
 - Placed on the left/right side of the opening and closing door for easy assembly, repair, and operation status check
- LAN, emergency switch, warning light connection terminal
 - LAN (RJ-45) : 10/100 Base, Required for external PC and communication connection, and can be operated by users by connecting drones and ground control systems (GCS)
 - Emergency switch : Stops the door opening and closing operation in an emergency.
 - Warning light: Display warning with a warning light during take-off and landing of the drone
- Caster(wheels) and fixed stand
 - It facilitates product transportation and movement, and the fixed stand enables steady operation even when operating the system

reference

When installing CUNA2, the station should be placed (installed) as flat as possible.

Adjust and fix the height of the support with clamps to keep it level.

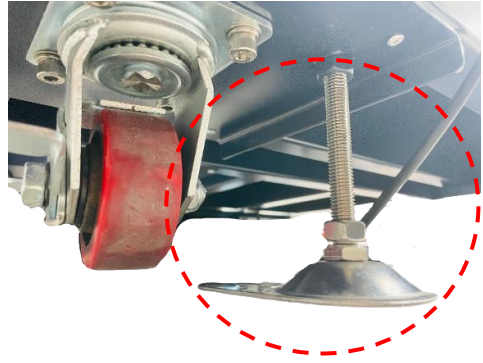

⑥ CUNA2 set up site conditions

- When installing, the floor should be level.
- When installing, the floor should be composed of concrete, etc., and the floor strength should be high (18Mpa or more).
- When installing, the floor should be at least 10 cm higher than the ground.
- For stable takeoff and landing of the drone, there should be no tall structures such as trees within a radius of 10 meters of the installation area.
- 220V power supply must be possible.
- Communication lines must be secured.
- Safety fences should be installed to prevent human or animal access

[Top view]

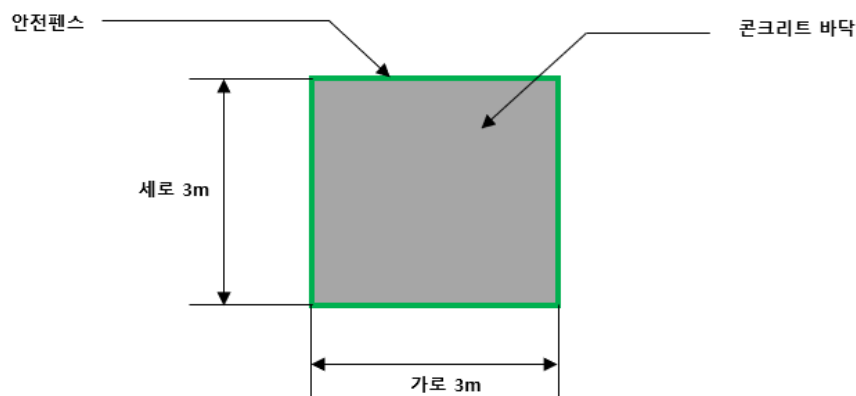

[Side view]

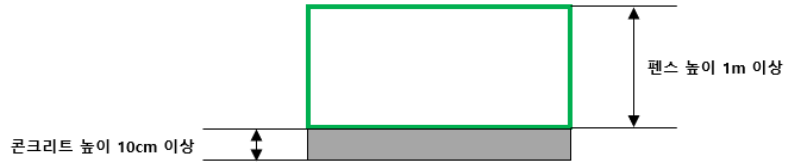

3. Operation



Wiring breaker

① Power on/off

- CUNA2 provides power to the station and internal devices by connecting the 220V power plug and then operating the off state of the main switch inside the side power management door to on.
- Operate the wiring breaker to 'on', then press the switch inside the station power management door to operate the station's PC.

② Drone precision landing

- With a vision system using infrared light, precise landing at the drone station is possible without the need for pilot control.
 - ※ Third-party drones can use this feature after installation of the RTK unit and a separate infrared landing control module.

- After receiving the command to land at the station, the drone descends and lands on the station accurately while finding the correct landing point on its own.
- When the precision landing guidance function is activated, it is confirmed that after the PC power is activated, the landing beacon LED on the station top lights up blue.

③ Drone automatic charging

- The charging pad and charging terminals on the drone landing skid come into contact to charge the battery without the need for the pilot to change the battery to keep the mission running.

Reference

If you use other products that do not have a charging function other than the drone products sold by the company, you cannot use the wired charging function.

4. Remote control

When CUNA2 is run by the Rondo Mobility System, it is controlled by the GCS program argosALES.

Stations are only connected via Cloud Link  .

① argosALES – Check the status through the GCS program

- After connecting and logging in to argosALES-P, you can connect the station and GCS.
- After connecting, information such as the station's starting status, location, altitude, orientation angle, and battery charge can be checked through GCS.
- You can manage multiple stations in one GCS by utilizing the 'Multiple Stations' registration function.

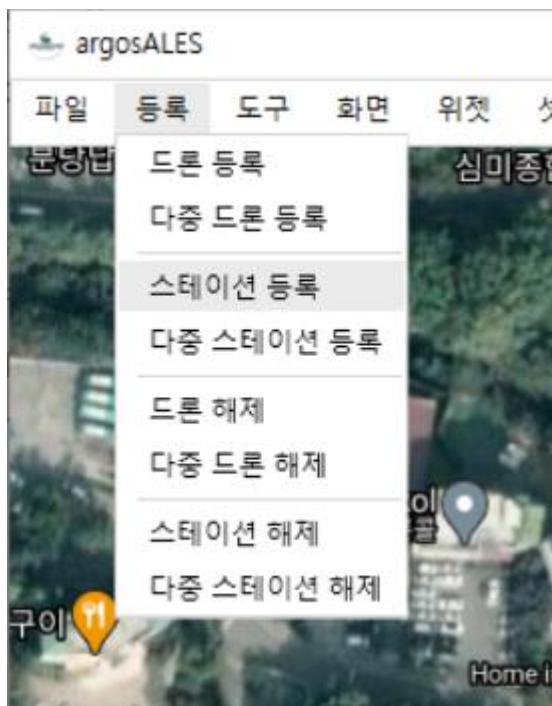

Reference

- * Stations installed on site must be powered on.
- * Station connection can only be accessed by stations assigned through a user authentication procedure in advance.

1) Register a Station

- In argosALES-P, in the 'Registration' tab, select 'Station Registration'
- In the registration window, check 'Device', 'Connection Type', and 'Device Name' as the settings that can be accessed, and then click the 'Register' button.

스테이션 등록

디바이스

드론 스테이션

연결 타입

IoT Hub MQTT
 TCP UDP
 RF Telemetry

IoT 디바이스 이름

Portus700-02

등록 취소

2) Check station connections

- Click the 'Device Information' window on the 'Screen' tab to check the status value of the registered station

If the station's location information is displayed and an icon  is displayed in the 'Communication status' section, it is a normal connection status.

아이	이름	타입	시동상태	버전	위도	경도	고도	방향각	배터리	위속	DOP	비행모드	통신방식	통신상태
1	uavTrooper2			N02.01.03	36.551830291748도	128.68310546875도	97.4m	132도	24.80V	23	0.7			
2	Portus700-03			S01.00.00	36.551830291748도	128.68310546875도	121.9m	0도	25.09V	0	0.0			

3) Unregister a station

■ Unregister drones and stations

- In the 'Registration' tab, select 'Unregister Station' to select the device you want to disconnect.
- Select the name of the device you want to release and press the 'OK' button to unregister it.

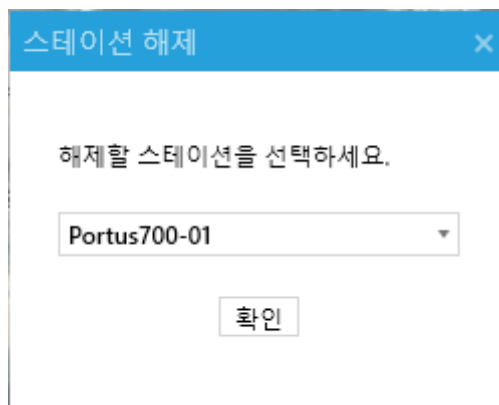



② argosALES – Operation control through the GCS program

1) Term Description

■ Station Status Information Monitoring: Station Table Screen Example



아이	이름	타입	시동상태	버전	위도	경도	고도	방향각	배터리	위상	DOP	비행모드	통신방식	통신상태
1	uavTrooper2			N02.01.03	36.551830291748도	128.68310546875도	97.4m	132도	24.80V	23	0.7			
2	Portus700-03			S01.00.00	36.551830291748도	128.68310546875도	121.9m	0도	25.09V	0	0.0			

- ID: Indicates an ID value that shows the connected order of the devices
- Name: Displays the name of the connected station
- Type: Displays the station.
- Start-up status: Displays the charging status.
- Version: Indicates the firmware version of the BirdCom board that is mounted on the station. The firmware must be kept up to date.
- Latitude: Displays the latitude value of the aircraft.
- Longitude: Displays the hardness value of the aircraft.

- Altitude: Indicates the value of the aircraft's absolute altitude from sea level.
- direction angle
 - 0/360° : North
 - 90° : East
 - 180° : South
 - 270° : West
- Battery: Numerically indicates the voltage of the battery installed in the aircraft.
- Number of satellites: The number of satellites recognized by the station's GPS.
A station operates normally with more than 16 GPS satellites.
- DOP: Displays the quality of the station's GPS. It works most accurately at 0.8 or lower.
- Flight mode: Indicates the ON/OFF status of the station precision landing sensor.
- Communication method: When registering a station, the connection type is indicated by an icon.
- Communication status: Displays the communication status of the station as an icon.
 - When connected normally , When connected abnormally  icon.

2) How to use the 'Station Control' panel

- In the 'Tools' tab, the station control window registered through 'Station Control' appears. The station control window registered through 'Station Control'
- The control window allows you to operate the current value, cut-off current, manually controllable mode settings and the door of CUNA2 when charging the drone.
 - Charging current: Set the current value received by the drone landing at the station when charging.
 - Cut-off current: Charging ends when the station is charged above a certain current.

- Manual charging mode: If the user checks the 'Manual charging mode' checkbox and activates (charges) the 'Charge' button, the 'starting status' is turned on  and starts charging as soon as the drone lands at the station correctly. Conversely, if the 'Charge' button is disabled (discharged), the 'Start-up' will switch to OFF  and the battery will not be charged unless otherwise commanded



- Manual door opening and closing mode: Used when the user wants to operate the station's door.
 - If you activate the icon with 'Door Open' while the station door is closed, and then press the 'Set' button, the station door will open
 - If you activate the icon with 'Door closed' while the station door is open, and then press the 'Set' button, the station door will be closed.
- Landing beacon control: The IR-Landing beacon installed for precision landing of the drone can be activated/disabled according to the user's needs.
 - If you press the 'Set' button after 'Beacon On', the landing beacon will turn on and precision landing will be possible.
 - If you press the 'Settings' button after 'Beacon Off', the landing beacon will turn off and you will be ready for other types of landings.

5. Reference

① CUNA2 Specification

Specification	
Size	* 1,135 x 1,096 x 1086(mm) (Included wheel height, Angle adjustment function)
Weight	* 170kg
Power	* 220V Single phase (13A)
Maximum drone landing size (based on landing skid)	* 660mm(W)*660mm(L)
PC	* Intel processor E3827, 4GB DDR3L-SDRAM, 40GB SSD
Landing Beacon	* Maximum detection range: 20+ meters * Beacon radiation angle: ~ 70 degrees
Positioning System	* GPS
Tops	Drone Alignment Actuator x 4, IR-lock (Precision landing), Automatic charging terminal, GPS antenna x 2, Cooling and heating tuyere
Cooling and heatine	* Cooling capacity: 550W * Heating capacity : 850W * Noise : 39 ~ 41dB
I/O Port	* 220V Main input power outlet
	* RJ45 Port (10/100 Base)
	* Port for emergency stop SW (6 pin)
	* Port for warning light (6 pin)
	* AUX terminal (6 pin)
Charging module	* Wired charging controller, wired charger (maximum output power 700W)
Software	* Remote control, remote monitoring
Option	* Battery maximum capacity prediction function, drone data download function

CUNA2 Option Details

- Battery maximum capacity prediction function – artificial intelligence algorithm-based prediction system
- Drone data download function – WiFi connection and data download function using landing drone

② Other notes

1. Precautions when charging the drone

- The drone uses only the battery specified by the manufacturer.
- The battery has a full charge voltage of $25.2\pm 0.4V$.
- The battery is based on 20 minutes per flight time and may not perform at its original performance after 100 charges/discharges.
- You can use the LIPO alarm (sold separately) to receive an alarm about the battery voltage.

■ Battery Care Precautions

- If the battery is exposed to liquids (rain, moisture) for a long time, the battery may catch fire or explode due to chemical decomposition.
- To prevent the battery from overheating, store it in a cool, dry place away from direct sunlight. If stored for more than 3 months, store at $22\sim 28^{\circ}C$ ($71\sim 82^{\circ}F$) temperature.
- Do not store batteries in environments with strong static electricity or electronic devices.
- Do not place heavy objects on top of the battery.
- If you plan to store the battery for a long time, fully charge and discharge the battery once every 3 months.
- If the battery is stored in a fully charged state for more than one week, problems such as swelling of the battery may occur, so discharge it to the storage mode of the battery charger for maintenance.

■ Precautions when using the station

- When installing the station, install it in a place where there is no magnetic field interference around it. The precision of automatic landing may decrease.

- When installing the station, install it in a place free from obstacles. There is a risk of landing unstable or falling due to collision or vortex phenomenon.
- Direct physical contact with the charging pad is prohibited. There is a risk of electric shock.
- When using third-party drones, please note the acceptable landing sizes.
- Do not climb directly on the station top or place anything other than a compliant drone (electronics, stones, liquids such as beverages, etc.). This may cause the product to fail.
- When setting up the station, adjust it so that it is level between the grounds.
- Do not attempt to move the landing guide arbitrarily or force it.
- When performing drone missions using the station, lock the door at the bottom of the station and use it. It may cause an accident.

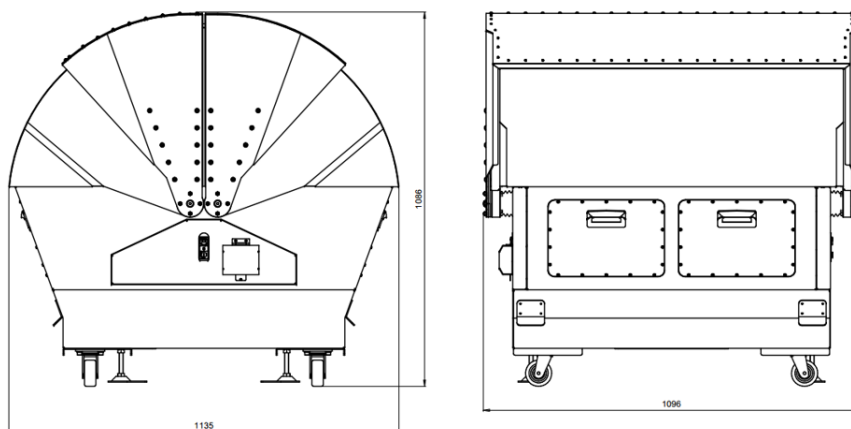

- This product can only be operated by specific personnel with specialized knowledge, The general public must never touch or manipulate it.
- This product is not intended for personal or commercial use.

7. FAQ and Customer support

Please check the FAQ for instructions for troubleshooting CUNA2 drone stations. For more information about your product, please use our Help Center.

- FAQ

Q: The station is not working.

A: check the following statuses.



- 1) Make sure the power plug is connected properly.
- 2) Check if the earth leakage breaker inside the power management door is lowered.
- 3) Check if the main switch inside the power management door is turned on.
- 4) Verify that the station registration is correct in argosALES
- 5) Checking the Link Status  of a Station in argosALES

Q: The drone does not start charging automatically.

A: Check the power connection status of the station. The station's main power must be on to start charging. If the main switch does not turn on the power, check the connection status of the power cable.

A: If charging does not start even though the station is turned on, check the status of the drone. Check the connection of the drone's battery power cable.

A: Make sure that the charging terminal mounted on the drone is in contact with the charging plate on the station top. If the grounding condition is unstable due to poor contact or foreign objects, charging may not start.

A: Make sure the startup status is set to ON  in the 'Device Information' window, if it is set to OFF , set it to 'Charging' in the 'Station Control' window of argosALES, and then make sure ON  is enabled in the Device Information window.

A: If all of the above items are correct, but the problem persists, please contact customer service.

Q: The drone does not land accurately at the station.

A: Please check if there are any magnetic structures nearby. If the drone's GPS sensitivity is low, it may affect the aircraft. If GPS sensitivity is constantly poor, it is recommended to move the station's location to operate.

A: Check the LED status of the GPS module mounted on the station top.
Due to communication shading, the signal sensitivity of the GPS may be poor, the accuracy of the station landing may be reduced due to abnormalities in the IR Landing Beacon or malfunction of the LIDAR sensor mounted on the drone. If you suspect or are in poor condition of these parts, we recommend that you stop operating the station and aircraft and seek service through the customer support center.

Q: What is the Rondo Mobility System?

A: Rondo Mobility System is Argosdyne's automated drone operation platform utilizing ground control system (GCS) + drone (UAV) + station. Rondo enables multiple drone control, integrated management between drones, multiple station control, automatic charging, and can control the execution of drones in various communication environments and conditions. Please contact the customer support center to inquire about building the system.

Q: Do I need heavy equipment to install the station?

A: CUNA2 weighs 170 kg and requires heavy equipment for long-distance travel and installation.

Q: Tell us about the mobile station.

A: Mobile station Portus is sized and weighed to be carried in vans, vans, etc., so it can be moved and operated in any position depending on the situation. And on flat terrain, the wheels make it easy to push and move the position. Typical stationary stations are difficult to change position easily once placed due to their weight. Mobile stations have the advantage of being able to quickly move and operate to the required area in situations where the area where the control mission must be performed is large or changes frequently.

Q: Tell us about the fixed station.

A: The fixed station CUNA2 can automatically return, charge and store the drone after performing the mission when regular and long-term control service operation is required at a designated location, and it is manufactured with a dome-type structure that allows the upper cover to open and close during the mission to take off and land, and to protect against external environments and dangers such as weather, theft, and damage after performing and returning to the mission. In addition, by minimizing the influence from the external environment, the need for airframe and equipment management through manpower can be reduced.

Q: Can argosALES check the location of stations as well as drones?

A: CUNA2 is equipped with GPS that allows you to determine the location coordinates of a station. If the station is connected to the Internet, argosALES can determine the exact location of the station and accurately select the mission flight path and landing site.

Q: Can I only use the station with a drone from Argosdyne?

A: By equipping the 'companion board' provided by Argosdyne, you can operate other companies' aircraft (drones). For reference, it is necessary to check whether the aircraft specifications, expansion slots, and programs are compatible with the aircraft you have. Please contact the customer support center to inquire about the use of third-party products.

A: Not necessarily, but at the moment only drones from Argosdyne can take advantage of the station's full capabilities. This is because in order to enable automatic charging, precision landing, and remote control with the station, the drone aircraft must also have a module paired with the station.

A: Depending on the structure of the aircraft, there are some products that cannot work, but the majority of medium-sized industrial drones can be linked to Argosdyne's stations through a separate work process. However, even in this case, it must meet the drone landing skid standards allowed by the station, so it is necessary to check whether it can be linked through a separate consultation.

- Argosdyne Customer Support Center

 070-5102-1388

CUNA2 Drone Station and Drone Automatic Operation System - For inquiries regarding the construction of the Rondo Mobility System, please use the Argosdyne Customer Support Center.

※ For customers using communication networks such as LTE/wifi through the Rondo Mobility System, problems related to the use of plans, etc. can be resolved by contacting the contracted carrier.

- Product Maintenance

The free maintenance period of CUNA2 drone station is one year from the date of purchase. Except in cases where the product itself is defective, free support is not provided for matters caused by the user's fault or natural disasters.

- Feedback on this article

To help us improve this article, please send us your suggestions, comments or errors to info@argosdyne.com.